



MONACO™ & MONACO RISER™

Operation Manual &
Product Specification Guide



Seating Matters™

CONTENTS

- 2. Safety Instructions
- 4. Technical Specifications
- 6. User Guide and Operating Instructions
- 12. Working Environment
- 13. Intellectual Property
- 14. Maintenance and Servicing

SAFETY INSTRUCTIONS

All instructions must be read and understood before the product may be used.

Terminologies

Patient: The person sitting in the chair

User: Competent person with responsibility for the persons sitting in the chair as well as the suitability of the equipment for the Patient. The User is responsible for checking the chair for faults during the course of its use.

- When the MONACO™/MONACO RISER™ is not in transit, all the braking castors on the product must be engaged to prevent risk of injury when being used.
- Under no circumstances must the User or Patient stand or sit on the footplate of the MONACO™/MONACO RISER™
- Where possible, the patient specific adjustments should be made when the Patient is not in the chair to avoid injury. These include seat depth and seat height adjustments.
- Care must be taken when making the adjustments on the chair to avoid injury to the User and Patient. Only a competent person should make adjustments to the chair. If in doubt as to any of the adjustments, feel free to contact Seating Matters direct at technical@seatingmatters.com.
- Keep all body parts away from the mechanisms under the chair. Repairs and maintenance should only be carried out by trained technicians.
- Exercise care in using the release lever for the reclining mechanisms and adjustments to avoid injury.
- The User must ensure that the patient has a period out of the chair after pro-longed sitting to raise tissue oxygenation levels. Although the chair offers maximum pressure management, the body tissue still needs time to recover. A maximum of two hours sitting is recommended at any one time. You must also observe Patient specific recommendations and guidelines as set by their health professional with regard to pressure care.
- For the safety of the User and Patient and to ensure longevity of the electronics on the powered options, please ensure that your MONACO RISER™ is charged daily using a Seating Matters charger through the handset of the chair. For further details or replacement chargers please contact your Seating Matters provider.
- The chair should not be transported in a vehicle while the Patient is seated on the chair.
- When operating the leg rest, recline and tilt in space features on the chair please ensure there is a 450mm gap at the front and back of the chair to prevent the back or leg rest coming into contact with a wall or any other object.

Assembly and installation instructions

- This chair should arrive fully assembled. The User must ensure that the product is in good condition before use (check all nuts and bolts are fastened, fabric in good condition etc.). If there are any problems, these must be reported to your Seating Matters provider and corrected before the chair is put into use.
- The product must be used on a level, plane, hard surface with the brakes engaged to avoid it moving during use and to ensure stability.
- The product must be clear of any obstacles before reclining the back to avoid damage to the chair and objects in its immediate environment.
- The product may not be left in an outdoor environment. More information on fabrics and their properties can be found on page 12.

MONACO™

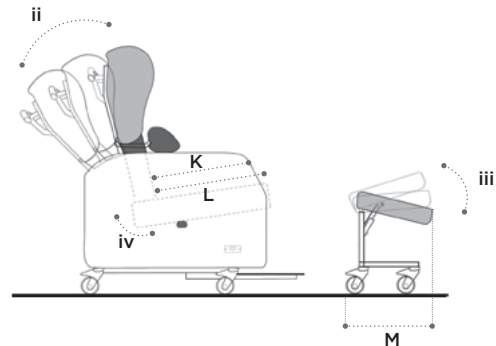
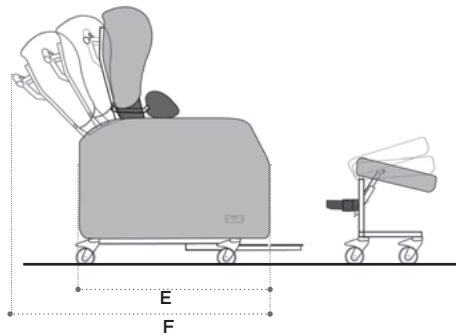
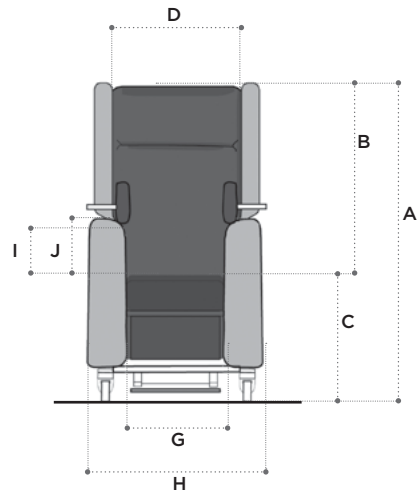

Basic dimensions

A	Overall height	1205mm/47.5in
B	Back height	800mm/31.5in
C	Seat to floor height	350-500mm/14-20in
D	Inside back width	505mm/20in
E	Chair length	870mm/34in
F	Reclined length	1090mm/43in

Available seat and overall widths

G (Seat width)	H (Overall width)
380mm/15in	645mm/25in
450mm/18in	715mm/28in
500mm/20in	715mm/28in
550mm/22in	765mm/30in
600mm/24in	815mm/32in

Arm height options*

I	Low	180mm/7in
J	High	210mm/8in

Recline and tilt angles

ii Back angle recline
110° - 135°
25° range
iii Leg rest angle
75° - 107°
32° range
iv Angle adjustable seat
0° - 20°
20° range

Seat depth options

K	Min	350-480mm/14-19in
L	Max	490-550mm/19-22in

Leg rest length

M	420mm/16.5in
---	--------------

Chair weight unloaded is 57 kg/125.6 lb/10.56 Stone.
*Please note when adapting cushion thickness arm height will be affected. Contact technical@seatingmatters.com for further information.

MONACO RISER™

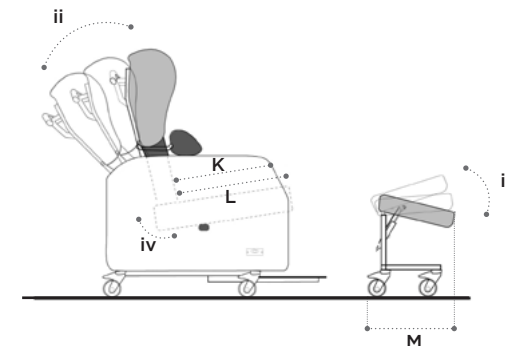
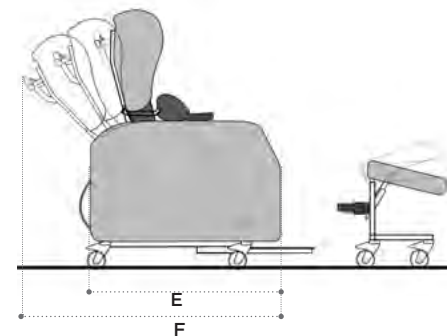
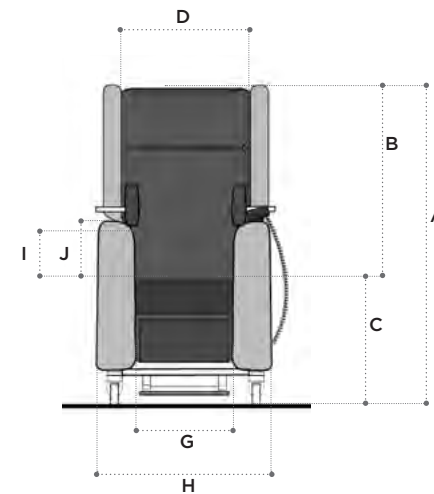

Basic dimensions

A	Overall height	1205mm/47.5in
B	Back height	860mm/34in
C	Seat to floor height	380-500mm/15-20in
D	Inside back width	505mm/20in
E	Chair length	870mm/34in
F	Reclined length	1090mm/43in

Available seat and overall widths

G (Seat width)	H (Overall width)
380mm/15in	645mm/25in
450mm/18in	715mm/28in
500mm/20in	715mm/28in
550mm/22in	765mm/30in
600mm/24in	815mm/32in

Arm height options*

I	Low	180mm/7in
J	High	210mm/8in

Recline and tilt angles

ii Back angle recline
110° - 135°
25° range
iii Leg rest angle
75° - 107°
32° range
iv Angle adjustable seat
-10° - +20°
30° range

Seat depth options

K	Min	350-480mm/14-19in
L	Max	490-550mm/19-22in

Leg rest length

M	420mm/16.5in
---	--------------

Chair weight unloaded is 57 kg/125.6 lb/10.56 Stone.
*Please note when adapting cushion thickness arm height will be affected. Contact technical@seatingmatters.com for further information.

USER GUIDE AND OPERATING INSTRUCTIONS

A competent person, trained in the use of the chair, should make adjustments and set it up according to the User requirements and Patient dimensions before the Patient sits in the chair. Ensure there is more than one competent person present when making adjustments to ensure they are correct and safe. Ensure all fixings are secure before allowing the person to sit in the chair, this includes lateral supports, seat adjustment and footplate. Please call your Seating Matters provider if you have any questions on these points. This product should not be lifted at any time unless by competent persons trained in such manual handling.

- **Braking Castors:**

The MONACO™/MONACO RISER™ must be used on a plane, hard surface with the brakes engaged to ensure stability and to avoid the device moving undesirably during use. Braking castors, where provided, must be in the braked position while in use (fig.1).

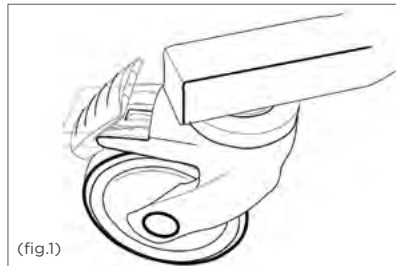

- **Back angle adjustment:**
MONACO™

To recline the back of the chair, the user must inform the Patient then stand behind the chair, and with two hands, firmly hold the push handle while closing the release lever (fig.2). Move the back of the chair slowly until it is in the required position and allow the release lever to move to its relaxed position before letting go of the push handles.

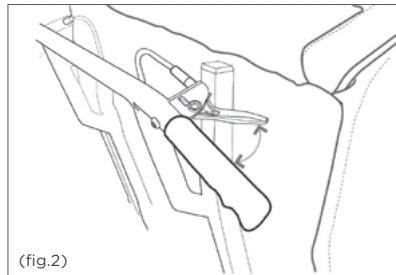

- **MONACO RISER™**

Adjustments are performed according to the buttons on the handset. (See page 10) Exercise care in case of injury to the Patient or damage to the surrounding environment.

- **Seat Angle Adjustment:**
MONACO™

To adjust the angle of the seat on the chair, the User must inform the Patient then stand behind the chair, firmly hold the push handle with your right hand and close the release lever located at the back of the chair (labelled TILT) with your left hand (fig.3). While closing the release lever place your foot on the step (labelled STEP) and push down until the seat is at the required angle and allow the release lever to move to its relaxed position before letting go of the push handles.

- **MONACO RISER™**

Using the handset adjust the seat angle to a desired position. The seat will elevate which will assist the patient to a standing position. The patient should be encouraged to use their armrests during this elevation for stability and balance.

Please note: do not change the angle of the seat before informing the patient sitting in the chair





(fig.4)

- **Seat depth adjustment:** To adjust the seat depth on the MONACO™ and MONACO RISER™ loosen the two wing knobs (fig.4 & 5) positioned under the seat of the chair, move the seat to the desired position and tighten the wing knobs again.

Please note: Do not attempt to adjust the seat depth while the client is in the chair.

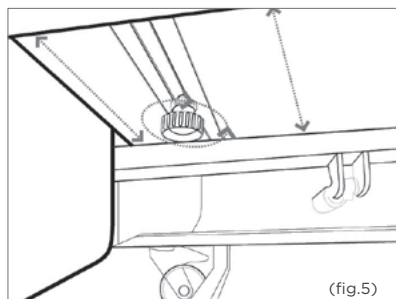

- **Seat height adjustment:** This adjustment is a factory setting. Please contact your Seating Matters provider for further adjustment.
- **Chair Movement:** To move the MONACO™ and MONACO RISER™ around, ensure the brakes are disengaged and push using the push handle on the back. Only a competent person should move this chair. Engage the directional lock castor on the front left of the chair to control the direction of movement and for ease of manoeuvrability.

- **Seat cushion:** The seat cushion on the MONACO™ and MONACO RISER™ is a waterproof, pressure redistributing, breathable, medium foam cushion providing pressure management and comfort. The seat cushion will have non-slip material on one face and a zip closure on one side. To fit the seat cushion to the chair, unwrap the cushion from the plastic packaging. Ensure the non-slip material is on the bottom and makes contact with the non-slip material already on the baseboard, with the zip closure at the rear. This is important as the foam's structure facilitates immersion and envelopment of the body prominences ONLY when fitted as instructed.
- **Sliding footplate:** At no point should anyone stand or sit on the sliding footplate. To use the sliding footplate pull it out to the full position and allow the feet to rest on it, ensuring they are placed on top of the sliding footplate. Push the footplate in to its fully retracted position before allowing the Patient to get on or off the chair, exercising care to stay away from the sliding rail. Adjust the footplate by holding the front lip.



(fig.6)

- Stand transfers:

MONACO™

Ensure the sliding footplate is fully retracted before allowing the patient to get on or off the chair exercising care to stay away from the sliding rail. Ensure the braking castors are engaged for stability and safety. The back recline and seat angle must be in a safe position before the Patient can perform the stand transfer. These functions are adjusted manually (see image with back recline and seat angle adjustment levers).

MONACO RISER™

Ensure the sliding footplate is fully retracted before allowing the patient to get on or off the chair exercising care to stay away from the sliding rail. Ensure the braking castors are engaged for stability and safety. Using the handset, adjust the back recline and seat angle to a desired position. The seat will elevate which will assist the patient to a standing position. The patient should be encouraged to use their armrests during this elevation for stability and balance.

- Hand control (MONACO RISER™):

The seat angle adjustment and back angle recline are controlled by the electric handset, simply push the button to operate the corresponding function.

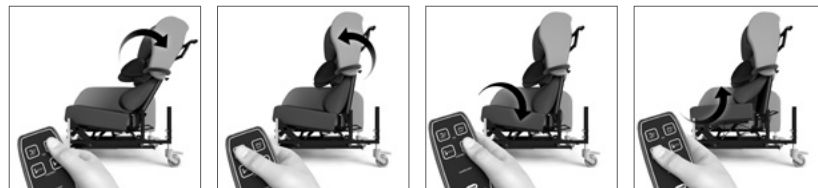

- Charging your chair (MONACO RISER™):

To charge your chair, plug the charger into a wall socket and plug the connector end of the charger into the charging socket on the side of the handset (fig.7). Charge the chair until the yellow light on the charger turns green. Do not operate the chair during charging.

IMPORTANT: PLEASE CHARGE YOUR CHAIR DAILY

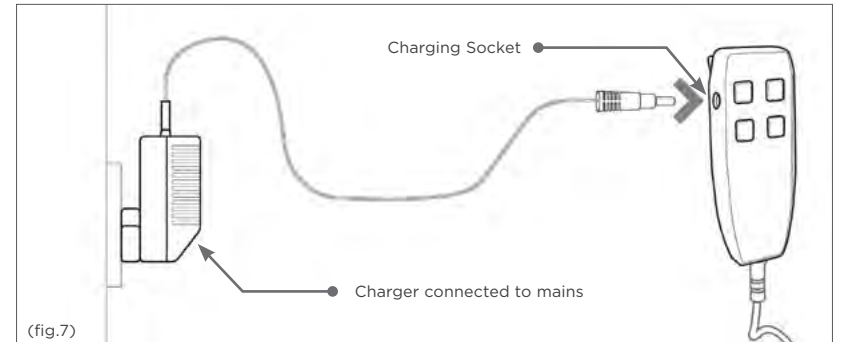

WORKING ENVIRONMENT

- **Dartex Multi-stretch:** Waterproof, stain resistant, flame retardant, multidirectional stretch fabric for pressure management situations – i.e. seat cushion, calf panels, lateral supports and seat back.
- **Vinyl:** Non-absorbent, anti-bacterial, flame retardant, strong, durable material for outer arms, outside back etc.

Cleaning and Maintenance of Fabrics

- **Vinyl (Arms and outside back):** Vinyl is resistant to urine, most household stains, mild acids/alkalis, drinks and beverages as they are not absorbed by the vinyl and can be wiped off without any problem or lasting damage. Some difficult substances such as lipstick, ball point pen ink and food colourings should be cleaned off immediately to avoid permanent staining.
- **Cleaning:** To ensure proper cleaning and longevity of the fabrics, the chairs should be cleaned with warm soapy water followed by a clean water rinse to help retain the attractive appearance and durability. Heavy, ingrained soiling may be removed by scrubbing with a soft brush. Strong detergents, solvent cleaners, polishes or patent chemical cleaners should not be used as they are unnecessary and may cause embrittlement and cracking of the material. Additional Care – special attention should be given to head rest and arm rest areas, as build-up of body oils in these areas will gradually cause the vinyl to harden.

Dartex Multi Stretch Fabric (Patient contact surface)

PROPERTIES: This fabric is waterproof, can be wiped clean and has biostatic (anti-mycotic) coatings to provide an impenetrable barrier to virus and bacteria. Superficial dirt may be removed by wiping with a soft cloth moistened with water containing a neutral detergent. More persistent contamination may be treated by wiping with alcohols or turpentine substitute, followed by hot water and detergent. Routine cleaning and disinfection in situ may be carried out on the coating with hand hot water and a neutral detergent or with a sodium hypochlorite solution (0.1% or 1000 parts per million available chlorine). The material is compatible with the 10,000ppm available chlorine in solution required for the decontamination of blood spills. Excess solution must be removed and the surface thoroughly rinsed and dried prior to reuse or storage. Proprietary disinfectants may be used provided manufacturer's instructions are followed. All cleaning agents, and disinfectants, must be thoroughly rinsed off and the item dried before storage. Failure to do this may result in damage to the polyurethane coating, react with the chair frame, or negate the biocompatibility results of the fabric. It is essential that articles be thoroughly dried after all cleaning procedures and before storage.

End of Life (Disposal)

Please contact Seating Matters for disposal of your chair at the end of its lifespan. Batteries may only be disposed of according to your local legal guidelines.

Safety

Both the MONACO™ and MONACO RISER™ are CE marked to show conformance to the Medical Devices Directive 93/42/EEC and conforms to BS ISO 7176 at medium hazard.

Regional Variations

The device referred to as a "Monaco™" / "Monaco Riser™" is a Seating Matters product category and the information included in this document reflects common features of this group of products. In some regions of the world, we supply product design variations of equivalent function and ease-of-use but with alternative specifications or reinforcements.

INTELLECTUAL PROPERTY

Seating Matters are at the forefront of seating research and design, therefore we take the protection of our intellectual property very seriously and have our designs, patents and trademarks protected in many jurisdictions throughout the world.

- **US Design Patent:** No. 601360S, No. D611718; No. 600932, No. D602704S.
- **Australian Design Registration:** No. 325536, No. 324011, No. 325537, No. 324012.
- **Community Design Registration:** No. 001016364-002, No. 000942180-0004, No. 002428813-0001, No. 001016364-001, No. 012673018.
- **Canadian Design Registration:** No. 130224, No. 128763, No. 130217, No. 128764.

MONACO™/MONACO RISER™ MAINTENANCE AND SERVICING

Regularly servicing your Seating Matters chair will prevent untimely and inconvenient breakdowns, reduce repair costs and extend the chair's life. Damage to the chair can also cause excess strain for the Patient and User.

Important

Parts can only be changed by service persons trained in Seating Matters products and use only Seating Matters parts. We recommend that your chair is serviced every year by a Seating Matters approved provider for any running repairs and maintenance.

Maintenance

Carry out the following regular checks to ensure the operation and safety of the chair. If you are in any doubt about the functioning of your chair contact your Seating Matters approved provider immediately.

Daily

- Check that the castors are not damaged.
- Check that the castors turn freely.
- Make sure that the castor forks run free and are not bent.
- Check all fabrics for damage or contamination and replace where necessary.
- See cleaning and maintenance of fabrics section in manual for cleaning instructions.

Weekly

- Check the castors fittings for hair and dirt etc. which could restrict the castor movement.
- Pick out any such material with tweezers or take the spindle out, clean it and then replace it.
- If it is still not free (one continuous turn without it sticking) contact your Seating Matters approved provider for replacement.

Monthly

- **Castors:** Make sure the top of the castor housing is parallel with the floor. Any variation will cause restricted movement. If it is damaged contact your Seating Matters approved provider for replacement.
- **Mechanisms:** Check all tilting mechanisms are working smoothly, check that all nuts and bolts are present and secure.

Please note: If nuts or bolts need attention, contact your Seating Matters approved provider IMMEDIATELY and DO NOT use the chair until it has been serviced.

- **Leg rests:** Check that all leg rests are easily removed/swung-away and replaced or repositioned easily. Ensure that parts lock in place securely. If parts are not locking try lubricating. If the problem still remains contact your Seating Matters approved provider.
- **Frame:** Check the visible parts of the frame for cracks, splits, large dents or other damage. If you find any of these things do not use. Contact your Seating Matters approved provider immediately.

WE ARE HERE TO HELP

For any questions or queries regarding your Seating Matters chair please contact: contact@seatingmatters.com

VIEW OUR FULL RANGE OF CHAIRS & ACCESSORIES ONLINE...

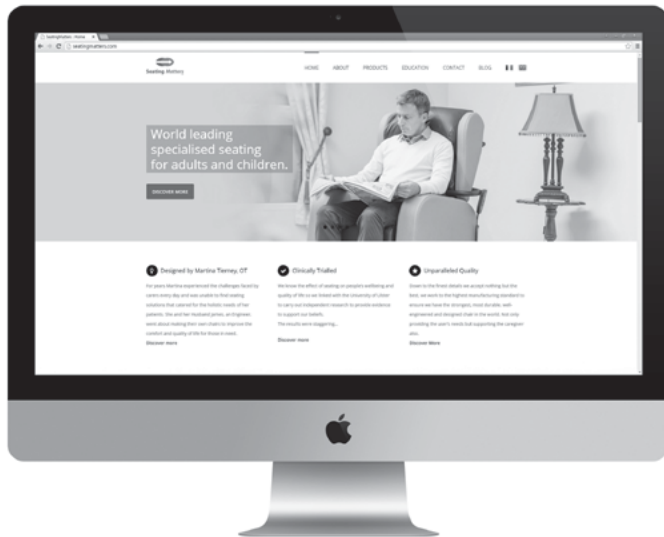

WWW.SEATINGMATTERS.COM



Australia

2/6 St James Place
Seven Hills,
NSW 2147
Australia

Tel: +61 1300 001 050
australia@seatingmatters.com

Canada

269 Maplegrove Rd
Colborne
ON, Canada
K0K 1S0

Tel: +1 (905) 507 9007
canada@seatingmatters.com

N.Ireland & ROI

131 Carnamuff Road
Limavady
Northern Ireland
BT49 9JG

Tel: +44 (0) 28 777 666 24
contact@seatingmatters.com

UK & Europe

Crown House
72 Hammersmith Rd
London, UK
W14 8TH

Tel: +44 (0) 20 7559 3555
london@seatingmatters.com

USA

300 International Drive
Suite 100
Buffalo, NY 14221
USA

Tel: +1 (905) 507 9007
ny@seatingmatters.com



Seating MattersTM

www.seatingmatters.com